

---

## Specification Sheet

CS-QCW-092011



### Passive Cooled Laser Diode Bars

**Up to 200W QCW**  
**Center Wavelength: 808-940nm**

---

#### Introduction

Apollo Instruments' high-powered laser diode bars deliver up to 200W in QCW. They are available in the following wavelengths: 808nm and 940nm.

The laser diode bars are built for maintenance free operation. Micro-channeled laser diodes are not used, which eliminate the need for de-ionized water, ultra-fine filter, and high-pressure pump. Thus it is suitable for robust industrial applications.

These diode bars have been demonstrated to be of high quality with long lifetime.

#### Key Features

- High power
- Long lifetime
- Low smile
- Narrow spectrum
- Wavelength 808nm & 940nm
- QCW operation
- Fast delivery time

#### Applications

- DPSSL & Fiber Laser Pumping
- Medicine
- Selective Soldering/Desoldering
- Heat Treatment
- Welding/Blazing
- Quick Cure of Epoxy
- Transformation Hardening
- And more

---

**IMPORTANT NOTICE:** APOLLO INSTRUMENTS, INC. RESERVES THE RIGHT TO CHANGE PRODUCT DESIGN AND SPECIFICATIONS AT ANY TIME WITHOUT NOTICE. NO LICENSE IS GRANTED BY IMPLICATION OR OTHERWISE UNDER ANY PATENTS OR PATENT RIGHTS OF APOLLO INSTRUMENTS, INC., OR OTHERS. THESE COMPONENTS DO NOT COMPLY WITH THE FEDERAL REGULATIONS (21CFR SUBCHAPTER 1) AS ADMINISTERED BY THE CENTER FOR DEVICES AND RADIOLOGICAL HEALTH. PURCHASER ACKNOWLEDGES THAT HIS/HER PRODUCTS MUST COMPLY WITH THESE REGULATIONS BEFORE THEY CAN BE SOLD TO A CUSTOMER. NO RESPONSIBILITY IS ASSUMED FOR THE USE OF THESE PRODUCTS, NOR FOR ANY INFRINGEMENT ON THE RIGHTS OF OTHERS RESULTING FROM THE USE OF THESE PRODUCTS. COPYRIGHT APOLLO INSTRUMENTS, INC. ALL RIGHTS RESERVED. Copyright©2004 Apollo Instruments

**Passive Cooled Laser Diode Bars – Specification Sheet**

CS-QCW-092011

**Specifications**

	Units	CS01/CS04 -150-808(Q)	CS01/CS04 -200-808(Q)	CS01/CS04 -200-940(Q)
<b>Optical Specifications <sup>3,7</sup></b>				
Center wavelength, $\lambda$	nm	808 $\pm$ 3	808 $\pm$ 3	940 $\pm$ 3
Output power <sup>2</sup>	W	150	200	200
Fill factor	%	83	80	75
Number of emitters	-	75	40	62
Emitter width	$\mu$ m	100	200	100
Spectral width FWHM	nm	$\leq$ 4		
Spectral width FW90%E	nm	$\leq$ 7		
Fast axis divergence (FWHM) <sup>4,6</sup>	$^{\circ}$	40		
Slow axis divergence (FWHM)	$^{\circ}$	8		
Polarization mode	-	TE		
Wavelength temp. coefficient	nm/ $^{\circ}$ C	$\sim$ 0.28	$\sim$ 0.28	$\sim$ 0.33
<b>Electrical Parameters <sup>3,7</sup></b>				
Operating current, $I_{op}$	A	$\leq$ 145	$\leq$ 200	$\leq$ 200
Threshold current, $I_{th}$	A	$\leq$ 25	$\leq$ 30	$\leq$ 20
Operating voltage, $V_{op}$	V	$\leq$ 2		
Slope efficiency	W/A	$\geq$ 1.1		
Power conversion efficiency	%	$\geq$ 50	$\geq$ 55	$\geq$ 50
Pulse width	ms	$\leq$ 0.3		
Duty cycle	%	$\leq$ 10		
<b>Thermal Parameters</b>				
Operating temperature	$^{\circ}$ C	15-35		
Storage temperature <sup>5</sup>	$^{\circ}$ C	-40 to 60		
Recommended heatsink capacity	W	$\geq$ 70	$\geq$ 100	$\geq$ 100

2. Reduced lifetime if used above nominal operating conditions.
3. Data at 25 $^{\circ}$ C temperature, unless otherwise stated.
4. For fast axis collimation: divergence <0.5 $^{\circ}$ .
5. A non-condensing environment is required for storage and operation below ambient dew point.
6. For smile requirements, please contact us.
7. If there are any other requirements, please contact us.

**IMPORTANT NOTICE:** APOLLO INSTRUMENTS, INC. RESERVES THE RIGHT TO CHANGE PRODUCT DESIGN AND SPECIFICATIONS AT ANY TIME WITHOUT NOTICE. NO LICENSE IS GRANTED BY IMPLICATION OR OTHERWISE UNDER ANY PATENTS OR PATENT RIGHTS OF APOLLO INSTRUMENTS, INC., OR OTHERS. THESE COMPONENTS DO NOT COMPLY WITH THE FEDERAL REGULATIONS (21CFR SUBCHAPTER 1) AS ADMINISTERED BY THE CENTER FOR DEVICES AND RADIOLOGICAL HEALTH. PURCHASER ACKNOWLEDGES THAT HIS/HER PRODUCTS MUST COMPLY WITH THESE REGULATIONS BEFORE THEY CAN BE SOLD TO A CUSTOMER. NO RESPONSIBILITY IS ASSUMED FOR THE USE OF THESE PRODUCTS, NOR FOR ANY INFRINGEMENT ON THE RIGHTS OF OTHERS RESULTING FROM THE USE OF THESE PRODUCTS. COPYRIGHT APOLLO INSTRUMENTS, INC. ALL RIGHTS RESERVED. Copyright©2007 Apollo Instruments, Inc. 55 Peters Canyon Road, Irvine, CA 92606 TEL) 949-756-3111, FAX) 949-756-9166 www.apolloinstruments.com

Dimensions Diagram (measurements in mm unless specified)

- CS01

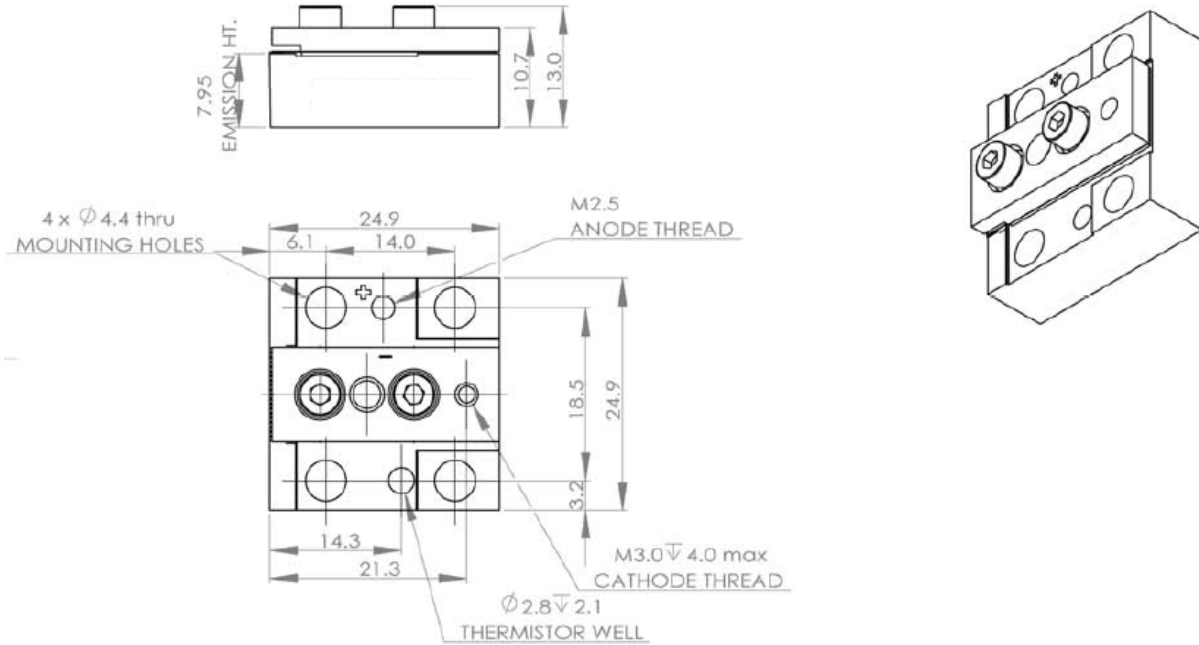

- CS04

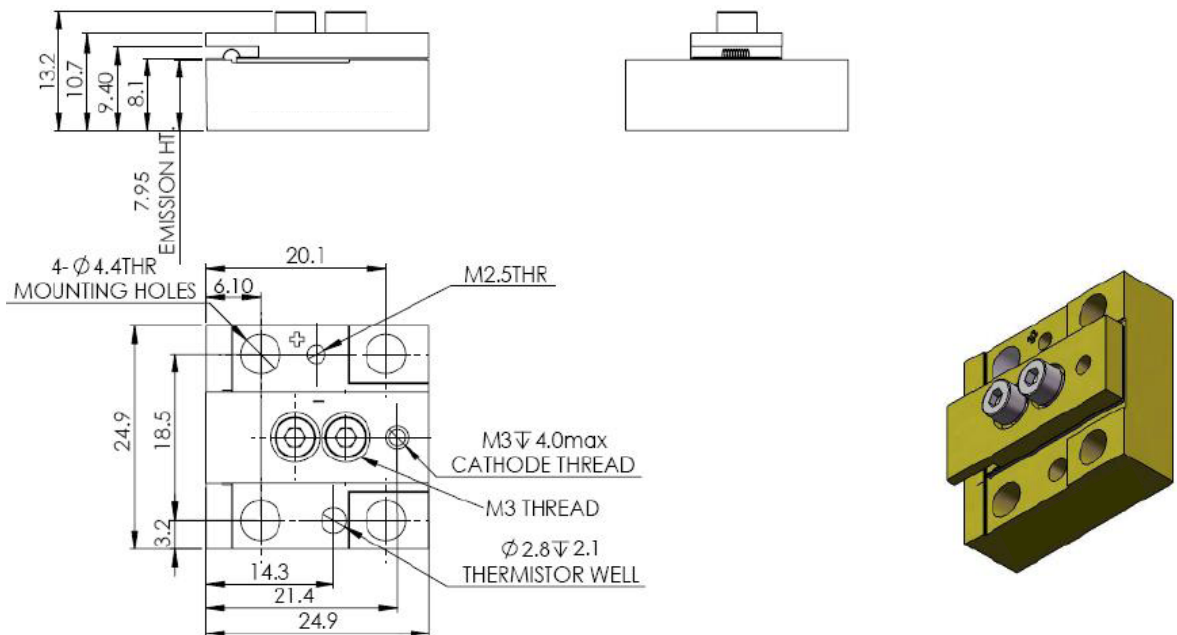

**IMPORTANT NOTICE:** APOLLO INSTRUMENTS, INC. RESERVES THE RIGHT TO CHANGE PRODUCT DESIGN AND SPECIFICATIONS AT ANY TIME WITHOUT NOTICE. NO LICENSE IS GRANTED BY IMPLICATION OR OTHERWISE UNDER ANY PATENTS OR PATENT RIGHTS OF APOLLO INSTRUMENTS, INC., OR OTHERS. THESE COMPONENTS DO NOT COMPLY WITH THE FEDERAL REGULATIONS (21CFR SUBCHAPTER 1) AS ADMINISTERED BY THE CENTER FOR DEVICES AND RADIOLOGICAL HEALTH. PURCHASER ACKNOWLEDGES THAT HIS/HER PRODUCTS MUST COMPLY WITH THESE REGULATIONS BEFORE THEY CAN BE SOLD TO A CUSTOMER. NO RESPONSIBILITY IS ASSUMED FOR THE USE OF THESE PRODUCTS, NOR FOR ANY INFRINGEMENT ON THE RIGHTS OF OTHERS RESULTING FROM THE USE OF THESE PRODUCTS. COPYRIGHT APOLLO INSTRUMENTS, INC. ALL RIGHTS RESERVED. Copyright©2007 Apollo Instruments, Inc. 55 Peters Canyon Road, Irvine, CA 92606 TEL) 949-756-3111, FAX) 949-756-9166 www.apolloinstruments.com

## Ordering Information

To make an order or request for further information on this or other products, please contact our sales representative by phone (949) 756-3111 or email [contact@apolloinstruments.com](mailto:contact@apolloinstruments.com).

## Laser Safety

High Power Diode Lasers emit radiation in the visible and infrared region of the spectrum. When in use, safety precautions should be taken to avoid possibility of eye damage. For Class IV lasers, extreme care must be exercised during their operation. Do not allow exposure of the eye or skin to direct or scattered radiation. If viewing is required, the beam should be observed by reflection from matte surface utilizing an image converter or a suitable fluorescent screen. Serious injury may result if any part of the body is exposed to the beam. The eye is extremely sensitive to the infrared radiation and therefore, proper eyewear must be worn at all times.

The laser products made by Apollo Instruments emit visible and invisible radiation power. The devices are intended for use by qualified personnel who recognize shock hazards or laser hazards and are familiar with safety precautions required to avoid possible injury.

ESD - Like most semiconductor devices, laser diodes can be easily damaged or destroyed by inadvertent electrical or static discharges. Laser Diodes are very sensitive to electrostatic discharge (ESD) and may suffer latent catastrophic damage unless they are handled according to proper ESD procedures. The resulting decreased performance of the laser may appear immediately, or long after the damage occurs. A

static free environment is mandatory. Grounded tweezers and a grounded wrist strap on the user, a grounded work surface, anti-static floors and case ground for the laser diode all reduce risk of damaging static discharge through the diode. Retain the laser diode in a static free environment when not in use (such as the shipping container). Short the diodes at all times when not in use. (Note: An unshorted laser can be damaged by ESD even without touching it!) The user should never try to service and repair the device without authorization of Apollo Instruments. Apollo Instruments is not responsible to any damages resulted by unauthorized repair and services. Any attempt to opening the laser unit will void the limited warranty to the device.